

DENON[®]

Dirac Live Room Correction Bass Control Active Room Treatment

Ensure that your AVR's firmware is up to date to access all functionality in this manual.



Getting Started

Dirac Live	3
Measuring with Dirac Live	4
Equipment required for Dirac Live Room Correction	4
Dirac Live licenses and features	6
Configuring AVR settings	7
Measuring with Dirac Live software	8
Creating a filter using an existing project file	18

How to use

Setting up Dirac Live on this unit	19
Dirac Live	19

Tips

Troubleshooting	20
Frequently asked questions	20
About Dirac Live Bass Control	23
About Dirac Live Active Room Treatment	24

Appendix

Inquiries	25
Trademark information	25



Dirac Live

This unit supports Dirac Live® Room Correction, Bass Control and Active Room Treatment.

Dirac Live license for Dirac Live Room Correction, Bass Control and Active Room Treatment ( p. 6) need to be purchased in order to use these services.

■ What is Dirac Live Room Correction?

Dirac Live is the leading digital room correction solution used in premium home theaters by applying state-of-the-art, patented algorithms that analyze and digitally reduce room impact and enhance speaker performance.

Dirac Live delivers a larger sweet spot, accurate staging, clarity, voice intelligibility, and a deeper, tighter bass not otherwise possible.

■ What is Dirac Live Bass Control?

Dirac Live Bass Control is a technology to manage low-frequency channel routing from the signal to the playback channels (speakers) of your audio device. Additionally, with full control over the device's channel and frequency routing and output, the Dirac Live Room Correction technology is significantly augmented. In particular systems with multiple subwoofers will see a substantially improved room correction and bass performance.

■ What is Dirac Live Active Room Treatment?

Dirac Live Active Room Treatment (ART) is an expanded version of Dirac Live Room Correction that calibrates your speakers as a unified system and uses each speaker's strengths to reduce room decay time, efficiently canceling out lingering bass and leading to unmatched clarity. ART stands above Bass Control and Room Correction as the most advanced product in Dirac Live.

■ Unique features of Dirac Live

- Runs on your PC/Mac computer
- User customizable target curves
- Save 3 customizable filters for easy comparison



- Refer to the information below to learn more about Dirac Live.

1. Dirac Live instruction top page
<https://helpdesk.dirac.com/>
2. Dirac Live software download page
<https://www.dirac.com/live/downloads/>
3. FAQ
<https://helpdesk.dirac.com/>



Measuring with Dirac Live

Equipment required for Dirac Live Room Correction

■ Computer (Windows or Mac)

You will need to install Dirac Live software on your computer in order to measure with Dirac Live Room Correction.

Your computer must have an internet connection.

■ Microphone for measurements

A USB microphone (sold separately) is required in order to measure with Dirac Live Room Correction. If your microphone comes with a calibration file, make sure the calibration file is available.

Recommended microphone: mini DSP UMIK-1*

* Download the unique calibration file for your UMIK-1 from the miniDSP web site by entering its serial number. **Please select the “_90deg” file.**

Calibration file download

Serial number: -

<https://www.minidsp.com/products/acoustic-measurement/umik-1>

NOTE

- The supplied Audyssey microphone is NOT compatible with Dirac Live.
- If you need a USB extension cable for the UMIK-1, please use an ACTIVE USB 2.0 or 3.0 cable.

Recommended USB Extension cable: Cable Creation Active USB Extension Cable 16.4 FT

<https://www.cablecreation.com/products/active-usb-extension-cable-16-4-ft>

■ Microphone stand

- For best results do NOT use the miniature mic stand that comes with the UMIK.
- Use a standard boom mic stand (sold separately).
- Do not hold the microphone in your hand while taking measurements.

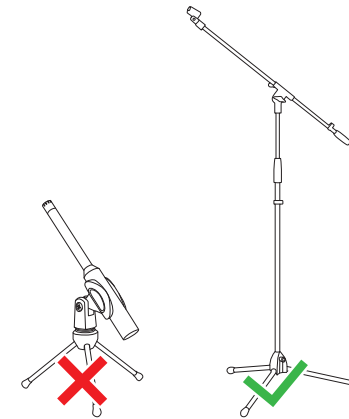

NOTE

- The microphone should be mounted on a stand facing the ceiling.

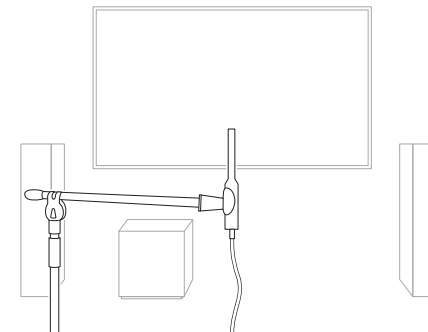

■ Dirac Live account, Dirac Live license and Dirac Live Software

If you are using Dirac Live Room Correction, you will need to create a Dirac Live account, purchase a Dirac Live license, activate your Dirac Live license and download Dirac Live software from following web page.

www.dirac.com/denon/



- You can create a Dirac Live account by selecting “Don’t have an account?” in the login screen of the Dirac Live web page.
- Make sure the Dirac Live software is updated to the latest version.
To check whether you are using the latest version, go to:
www.dirac.com/live/downloads/

To make sure your AV receiver is updated to the latest version, go to Setup Menu, select, General, Firmware and then Check for Update.



Dirac Live licenses and features

The features available to you in the Dirac Live software differ depending on the license you purchase. Below are the features available with each license.

■ When using your system without subwoofer

	License	
	Dirac Live Room Correction	Dirac Live Room Correction and Dirac Live ART*2
Filter options available in the Dirac Live software	<ul style="list-style-type: none"> • Dirac Live*1 	<ul style="list-style-type: none"> • Dirac Live*1 • ART

*1 Dirac Live refers to the Dirac Live Room Correction feature.

*2 You will need both Dirac Live Room Correction and Dirac Live Active Room Treatment licenses to use the ART feature.

■ When using your system with a subwoofer

	License		
	Dirac Live Room Correction	Dirac Live Room Correction and Bass Control*3	Dirac Live Room Correction, Bass Control and Dirac Live ART*4
Filter options available in the Dirac Live software	<ul style="list-style-type: none"> • Dirac Live*1 • Bass Management*2 	<ul style="list-style-type: none"> • Dirac Live*1 • Bass Management*2 • Bass Control 	<ul style="list-style-type: none"> • Dirac Live*1 • Bass Management*2 • Bass Control • ART

*1 Dirac Live refers to the Dirac Live Room Correction feature.

*2 “Bass Management” refers to the Dirac Live bass management feature that is available to users who purchase the Dirac Live Room Correction license.

*3 You will need both a Dirac Live Room Correction license and a Dirac Live Bass Control license to use the Bass Control function.

*4 You will need three licenses, Dirac Live Room Correction, Dirac Live Bass Control, and Dirac Live Active Room Treatment to use the ART feature.



Configuring AVR settings

Before using Dirac Live software, follow the steps below to set up this unit.

1 Connect to a network.

Connect this unit and the computer where Dirac Live software is installed to the same network.

(Setting items: Setup Menu - Network - Connection)

2 Set the speaker preset (excluding the first time measurement is performed).

Select the speaker preset where you want to save the measurement results. If two speaker presets are already being used, the speaker preset you have selected will be overwritten with the measurement results.

When performing calibration with Dirac Live for the first time, saving to Speaker Preset 2 is performed automatically.

(Setting items: Setup Menu/Speakers/Manual Setup/Speaker Preset)

NOTE

- When performing calibration with Dirac Live for the first time, the Speaker Layout and Crossover values from Preset 1 are copied.
- When performing calibration with Dirac Live for the first time, overwriting is performed even when Preset 2 is in use.

3 Set the speaker layout.

Set the layout of the speakers you want to measure in Speaker Layout in the menu.

(Setting items: Setup Menu - Speakers - Manual Setup - Speaker Layout)

NOTE

- The optional Dirac Live room correction feature calculates the proper gain and delay time for each speaker, however it does not calculate the crossover points. Please adjust the crossover points for your speakers using the AVR's Setup Menu before performing Dirac Live calibration.
Setting Item : Setup Menu – Manual Setup – Crossovers
- Crossovers are automatically set to a suitable setting when using Bass Management or Bass Control. "9-2 If using Bass Management or Dirac Live Bass Control™" (☞ p. 14)
- To use ART, the settings are automatically optimized by applying the ART parameters instead of crossover frequency in order to maximize the capabilities of your speakers. "9-3 If using Dirac Live Active Room Treatment" (☞ p. 15)
- The measurement cannot be conducted when headphones are connected. If headphones are connected, unplug them before performing the Dirac Live measurement.



Measuring with Dirac Live software

The Dirac Live software is used for the measurement. Follow the instructions in the Dirac Live software to take the measurements.

1 Start the Dirac Live software on your PC/Mac.

2 Log in to your Dirac Live account.



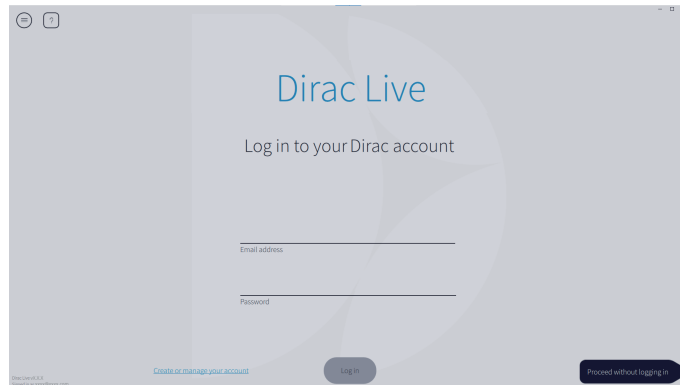

Enter the account details you created on the Dirac Live website.

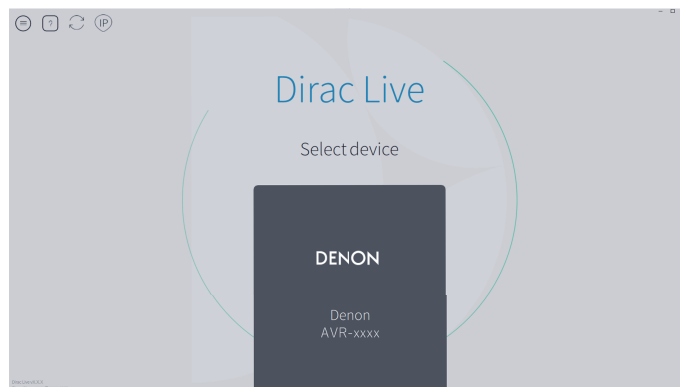

3 Select the product you want to take measurements for.

The software detects products compatible with Dirac Live on the same network as the computer and displays them on the screen.





- If this unit cannot be found, click  (Rescan). Make sure your PC/Mac is on the same network as your AVR.
- Click the  (IP) button to detect this unit manually by entering the IP address.
- Click the  (Menu) button to display the menu. This allows you to select the language and save and import projects.
- Click the  (Help) button to view a help page for each screen.

■ If you have already taken measurements with Dirac Live

You can skip the measurement process by loading the project file you saved with your previous measurements after selecting this unit. “Creating a filter using an existing project file” ( p. 18.)



- When you load the project file, you can use new filter options like Bass Control or ART to create filters based on your previous measurement results. “9-2 If using Bass Management or Dirac Live Bass Control™” ( p. 14.), “9-3 If using Dirac Live Active Room Treatment” ( p. 15.)



4 Connect the microphone that will be used for the measurements to a USB port on the computer or this unit.

The microphone is displayed in the Dirac Live software when it is connected.

■ If connecting the microphone to the computer

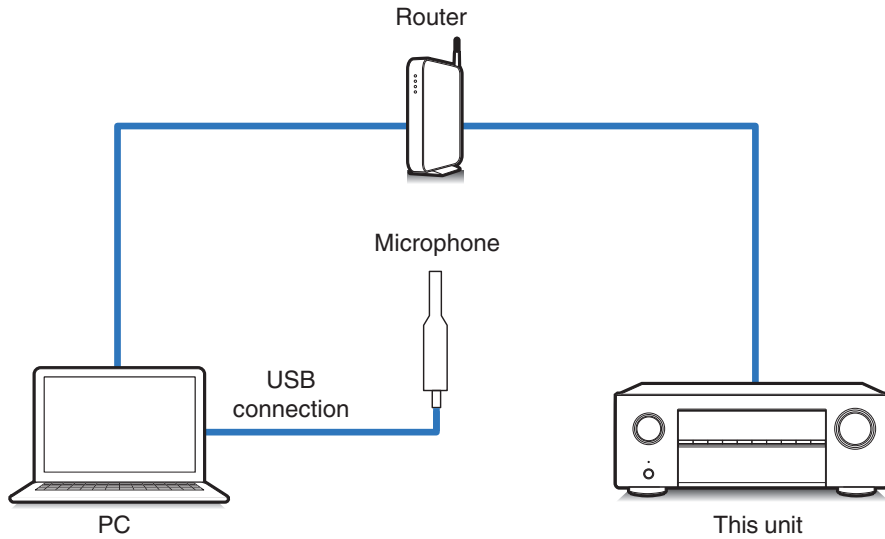

■ If connecting the microphone to this unit

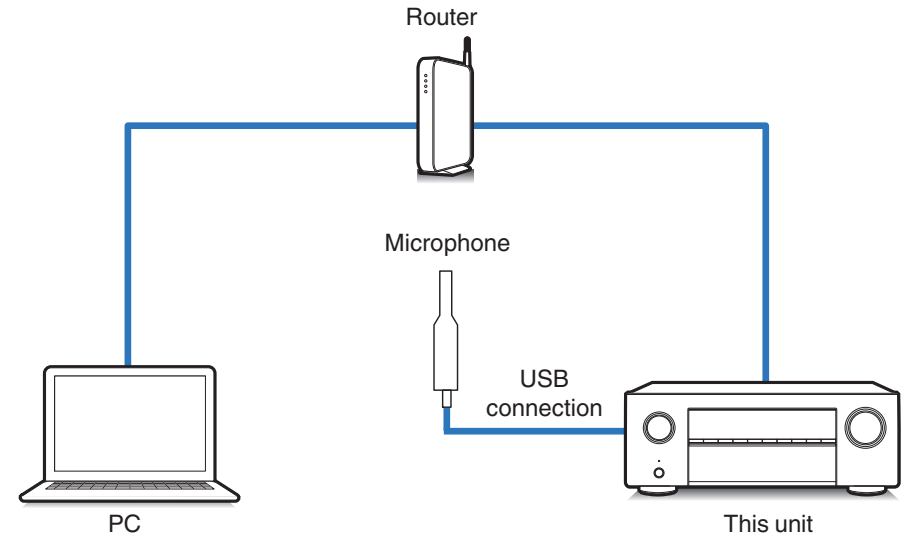

NOTE

- If your unit has two USB ports, connect the microphone to the USB port on the front panel.



5 Select the microphone you will use for the measurements.

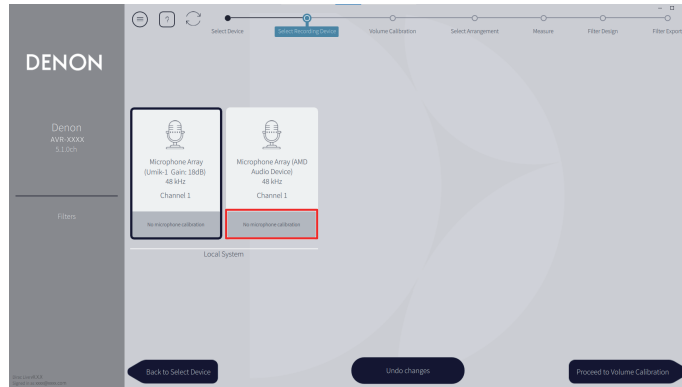

If the microphone you are using for the measurements comes with a calibration file, you will need to load the calibration file in the Dirac Live software too.

- Click “No microphone calibration” of the microphone (shown in red) to load the calibration file.

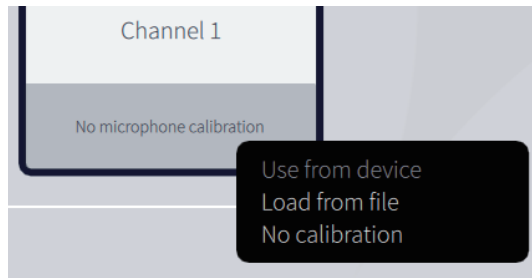

After selecting the microphone, click “Proceed to Volume Calibration”.

NOTE

- The internal microphone of the computer and other recording devices connected by USB are also displayed. Be sure to select the microphone you connected for these measurements.

6 Adjust the output level for the measurements and the input level for the microphone.

Adjust the output of all of the speakers that are connected to a suitable level so that proper measurements can be taken.

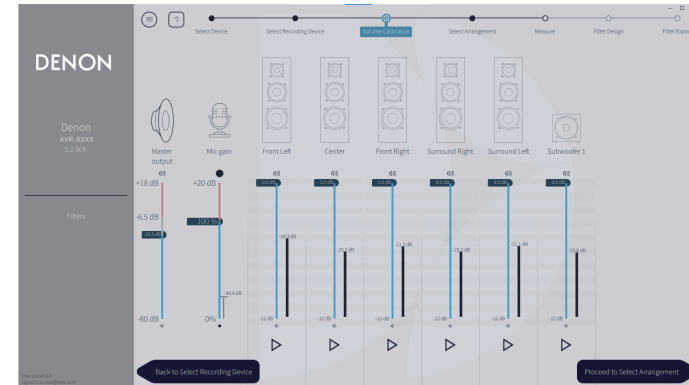

- ① Put the microphone you will use for the measurements on the microphone stand and place the stand at the main listening point.
Point the tip of the microphone toward the ceiling and adjust the height to match the height of the ears of a listener in a seated position.
- ② Set Mic gain to 100%.
- ③ Set Master output to around -55.0dB.
- ④ Select one speaker and press the ▷ button.
A test tone will be output from the speaker you selected and the audio that is detected will be displayed on a level bar.
- ⑤ Adjust the master output so that the audio that is detected is around -15.0dB to -30.0dB.
- ⑥ Play the test tone of the next speaker and check that the output displayed in the level bar is between -15.0dB and -30.0dB.
If it is outside this range, adjust the output level using the volume controls for each channel in the Dirac Live software.
- ⑦ Repeat step 6 for all of the speakers and adjust each speaker so that the output level is between around -15.0dB and -30.0dB. When you have finished adjusting the output levels, click “Proceed to Select Arrangement”.

NOTE

- The output displayed on the level bar is a guide only, and the level bar may not reach -30dB depending on your computer or environment. In this case, adjust all channels to approximately the same level.
Set the volume level a little higher than the level you would typically use.

**About the main listening position**

- The main listening position is the position where listeners would normally sit or where one would normally sit alone within the listening environment.
- To ensure that the measurement results are correct, put the microphone for measurement on a microphone stand.

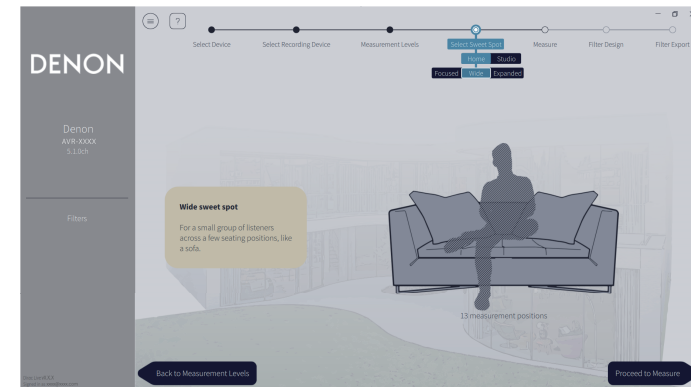
7 Select a listening area

After selecting the listening area, click “Proceed to Measure”.

NOTE

- Use the “Wide Imaging” arrangement in Dirac Live if your room has more than one row of seating or is large enough for more than two people.



8 Take the measurements.

Take measurements in each position.

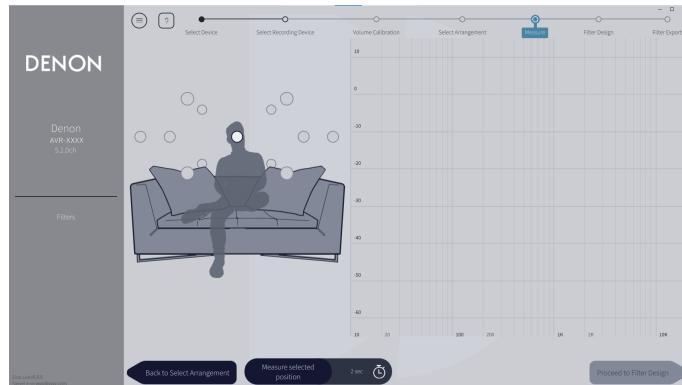

- ① Put the microphone you will use for measurement in the main listening position and point it straight upward.
- ② Select the circle in the center of the illustration on the screen.
- ③ Click “Measure Selected position”.
A test tone will be output from each speaker and the measurement will start.
- ④ When the measurement is finished, move the microphone to the next position.
- ⑤ Select the next position on the screen and take the measurement.
- ⑥ Repeat steps 4 and 5 to take measurements in all of the positions.
When you have finished taking the measurements, click “Proceed to Filter Design”.

NOTE

- You can proceed to the next step (“Filter Design”) without taking measurements in every position. However, we recommend taking measurements in every position, because the more measurements that are taken, the more accurate the calibration is.
- Keep the room as quiet as possible during measurements. Other noise will interfere with measurements. Close the windows and turn off electrical products (radios, air conditioners, fluorescent lights, etc.) Noise from these products may affect measurements.
- Do not stand between the speakers and the microphone or place large items there while taking measurements.



9 Adjust the filters.

Adjust the filters of each channel.

■ Filter options

The features of the filter options that can be selected in Dirac Live software are as follows.

- “Dirac Live” is a digital room correction technology that employs a sophisticated analysis of your speakers and listening room.
- “Bass Management” directs bass frequencies from all input channels to one or more subwoofers.
- “Bass Control” is a measurement based bass management where both speakers and subwoofers are viewed as a complete system.

9-1 If using Dirac Live Room Correction

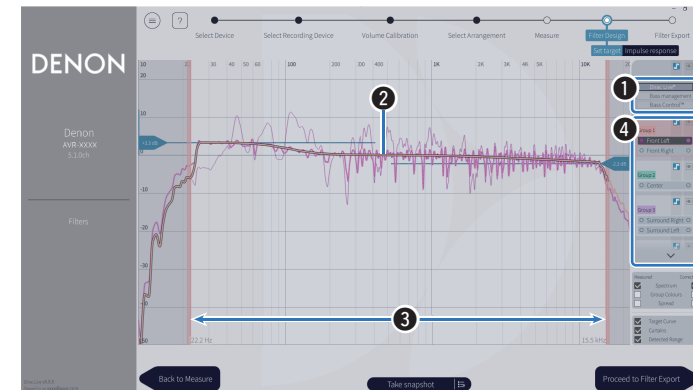

1 Filter options

To use Dirac Live Room Correction as the filter design, select Dirac Live®. Filters are calculated after they are selected, so it may take a while for the full results to be displayed.

2 Target curve

The target curve is the curve used to decide the frequency characteristics of the speakers after calibration by Dirac Live. You can adjust the target curve according to your preferences.

3 Curtains

Use the sliders on the screen to adjust the frequency range across which the filter will be applied.

4 Speaker selection

Select the speaker for which you want to edit the target curve. You can also group together specific speakers. The same target curve will be applied to all of the speakers in the group.

When you have finished adjusting the filters, click “Proceed to Filter Export”.

NOTE

- “Crossovers” are not calculated by the Dirac Live software when Dirac Live is set as the filter option. Set them manually on the unit if necessary.



9-2 If using Bass Management or Dirac Live Bass Control™



1 Filter options

Select Bass Management or Bass Control™ as the filter design. Filters are calculated after they are selected, so it may take a while for the full results to be displayed.

2 Target curve

The target curve is the curve used to decide the frequency characteristics of the speakers after calibration by Dirac Live. You can adjust the target curve according to your preferences.

3 Curtains

Use the sliders on the screen to adjust the frequency range across which the filter will be applied.

4 Speaker selection

Select speakers to edit the target curve and crossover point. You can also exclude a group of speakers from Bass Management or Bass Control by dragging them to Unmanaged Channels.

5 Crossover point

Adjust the crossover frequency of the selected group of speakers.

A, defines which frequencies are assigned mainly to the subwoofers.

B, both subwoofers and high-range speakers will receive the frequencies.

C, defines the frequencies that are assigned mainly to the high-range speakers.

6 Calculate (Bass Control™ only)

If Bass Control™ is selected as the filter option, press the Calculate button to calculate the filter.

When you have finished adjusting the filters, click “Proceed to Filter Export”.



Bass Control and Bass Management

The filters that can be used will differ depending on your license.

- Bass Control is fundamentally different from traditional bass management solutions. Bass Management is a common AVR function that extracts bass content from input signals and routes it to connected subwoofers. Bass Control does offer bass management functions, but the core value of Bass Control is that it co-optimizes speakers to improve bass accuracy and ensures consistent bass performance throughout the listening area from a single- or multiple-subwoofer setup. Put simply, each subwoofer is tuned as part of a complete unit in your listening space, leading to a consistent and realistic response, no matter the arrangement.
- For more details on Dirac Live, see Dirac Live Support. <https://helpdesk.dirac.com/>

NOTE

- The optimal “Distances”, “Levels” and “Crossovers” are calculated by the Dirac Live software when Bass Management or Bass Control™ is set as the filter option. These settings cannot be changed after the filter is sent to the unit and enabled on the unit. “Dirac Live” (p. 19)



9-3 If using Dirac Live Active Room Treatment



1 Filter options

Select ART™ as the filter design. Filters are calculated after they are selected, so it may take a while for the full results to be displayed.

2 Target curve

The target curve is the curve used to decide the frequency characteristics of the speakers after calibration by Dirac Live. You can adjust the target curve according to your preferences.

3 Speaker selection

Select the speaker for which you want to edit the target curve. You can also group together specific speakers. The same target curve and ART parameters will be applied to all of the speakers in the group.

4 ART settings button

The ART parameter settings box will open.

5 ART parameter settings box

The ART parameter settings box is assigned to each speaker box. The Dirac Live software automatically assigns the optimal value to parameters according to the measuring results. No need for users to change any settings. When you want to change the settings manually, see the setup guide in Dirac Live Support. <https://helpdesk.dirac.com/>

NOTE

- When setting the ART parameters manually, check the specifications of your speaker to ensure that the parameter settings do not go below the playback frequency of your speaker.
- Since there is a limit to the total number of speakers that are included in the group you have selected, you may not select some groups depending on the layout of your speakers. In that case, Dirac Live Software will automatically select the appropriate group enabling you to get the full effect of the ART filter. If you would like to select a group manually, clear the existing group selection and then choose your preferred group.

6 Calculate

When you have completed the settings, click the Calculate button. It may take a longer time to calculate depending on the performance of your PC or the network environment

When you have finished adjusting the filters, click “Proceed to Filter Export”.

NOTE

- If ART™ is specified as the filter option, the optimal “Distances” and “Levels” will be calculated by the Dirac Live software. Bass management will be automatically adjusted using ART Parameters, instead of “Crossovers”. These settings cannot be changed after the filter is sent to the unit and enabled. “Dirac Live” (🔗 p. 19)



10 Export a filter to this unit.

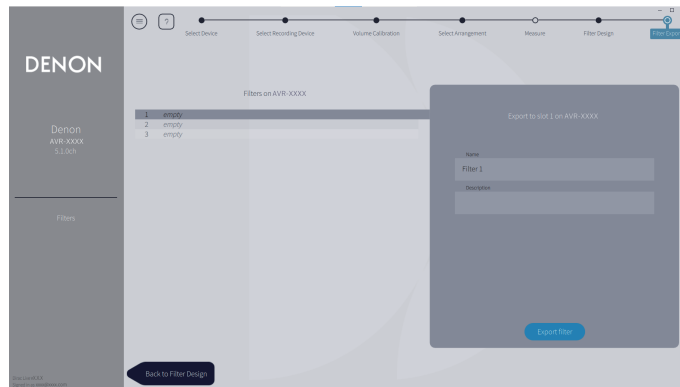

- ① Select the slot of a filter you want to export.
- ② Enter a name for the filter.
You can enter any name in Dirac Live software, but this unit has a character limit. We recommend entering a name that is 20 characters or less.
- ③ Click Export Filter.
The filter is exported to this unit. The Filter Design page is displayed automatically when the export is completed.

11 Create multiple filters.

Up to three filters can be created in Dirac Live according to the measurement data. After creating new filters in the Filter Design page, select the numbers of unused slots in the Filter Export screen and export the filters.



- The following screen appears in the display (GUI) of this unit while the unit is communicating with the Dirac Live software. This unit cannot be operated while this screen is displayed.
- If a network issue or other issue disrupts the process while this screen is displayed, press the BACK button on the remote control to return this unit to normal mode and start the Dirac Live software again.

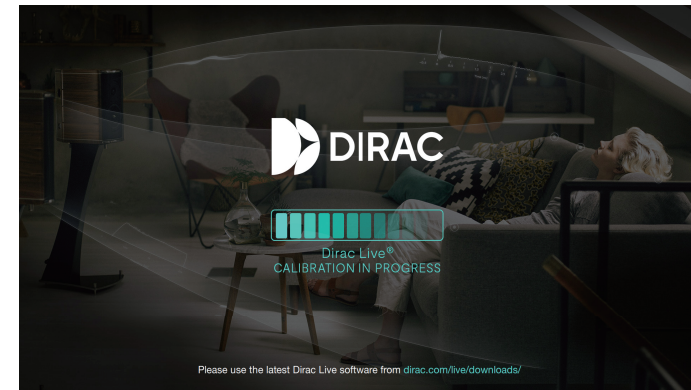

NOTE

- You can save and import measurement projects at any time from the menu in the Dirac Live software. Saving a project file allows you to resume measurements if they are interrupted or export measurement results again if necessary.
- When importing a project file, set the speakers of this unit in the same layout as when the project file was saved.
- If you try to overwrite an exported filter with the same filter after editing it manually, there may be some cases in which the saved settings are not applied. In this case, select the filter you want to overwrite from “Filter” displayed in the lower left of the Dirac Live software screen. The filter can be deleted from this unit by clicking the X mark. Then export a new filter.

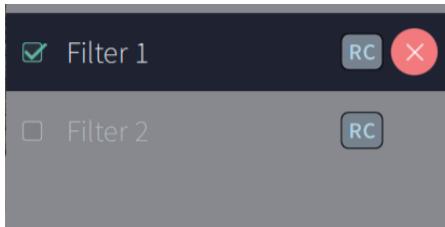

Creating a filter using an existing project file

If you have a project file with earlier measurement results, you can load this project file to adjust a filter without taking measurements.

1 Select the menu in the Dirac Live software.

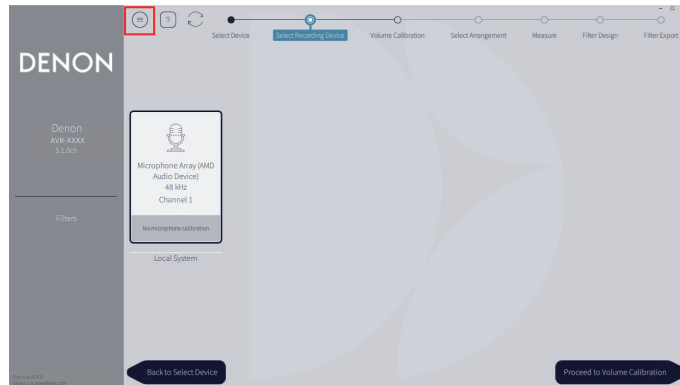

3 Adjust the filter

After the project is loaded, a screen to adjust the filter opens. Adjust the filter for each channel. “Adjust the filters” (👉 [p. 13](#))

2 Load the project file

Select Load Project in the menu and then select the project file you want to use. (The file must have the extension “.liveproject”.)

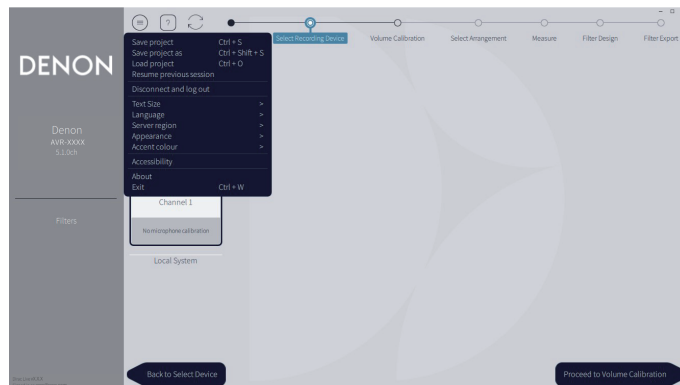

Setting up Dirac Live on this unit

Dirac Live

Filters exported from the Dirac Live software can be set by selecting Audio - Dirac Live in the Setup Menu.

These settings are enabled after the filter is sent to the unit from the Dirac Live software.

Slot 1*:	The Dirac Live filter that was exported to Slot 1 will be used.
Slot 2*:	The Dirac Live that was exported to Slot 2 will be used.
Slot 3*:	The Dirac Live that was exported to Slot 3 will be used.
Off:	Dirac Live filter will not be used.

* Filter names created in Dirac Live Software will be displayed in the user interface.



- You can store a maximum of 3 filters when using Dirac Live Software.
- Only the slot to which the filter was exported can be selected.
- In addition to acoustic filters that correct frequency and time responses, Dirac Live also stores the output level and distance of each speaker for each filter.
- The Dirac Live filter settings are stored for each input source.
- When the sound mode is "Direct" or "Pure Direct", only Distances and Levels will be applied. The acoustic filter will not be applied.
- Dirac Live is automatically turned off when headphones are used.
- Graphic EQ cannot be set when Dirac Live is being used.
- You can also set filters in Option Menu - Dirac Live.

1. Press OPTION.

An option menu screen is displayed.

- When the input source is "HEOS Music", an option menu for online music is displayed. Select "AVR Options...", then press ENTER.

2. Use cursor Up/Down to select "Dirac Live", then press ENTER.

The "Dirac Live" screen is displayed.

3. Use cursor Left/Right to select your favorite filter.

NOTE

- Dirac Live setting data will be deleted when the speaker configuration is changed in "Speaker Layout" in the menu after performing Dirac Live Room Calibration. The measurement must be performed again if the speaker configuration has changed. If the Dirac Live[®] filter option is applied to the filter you have set, you do not need to measure "Distances", "Levels" and "Crossovers" again when making changes after the initial Dirac Live measurement.
- If Bass Management, Bass Control or ART is set as the Dirac Live filter option for the unit, the following restrictions apply.
 - The following settings under Speakers - Manual Setup in the Setup Menu cannot be changed.
 - Distances
 - Levels - Test Tone
 - Crossovers
 - When using ART, you cannot enter the crossover frequency menu because dedicated parameters are used.
 - Speaker Layout - Subwoofer Mode
 - Speaker Layout - Subwoofer Layout
 - Advanced - Low Frequency Effects
 - Advanced - 2ch Playback
 - Audio - Subwoofer Level Adjust in the Setup Menu cannot be changed.
 - Audio - IMAX Audio Settings in the Setup Menu is set to Auto and cannot be changed.
 - Dialog Enhancer and Tone can not be used in the Options Menu.
 - In the following sound modes, Distances, Levels and Crossovers can be applied as filter options. Acoustic filters are not available. (When using ART, the crossover frequency when Dirac Live is turned off will be applied.)
 - Multi Ch Stereo
 - Rock Arena
 - Jazz Club
 - Mono Movie
 - Video Game
 - Matrix
 - To use these restricted functions, turn off Dirac Live or select a filter where Dirac Live Room Correction is applied.



Troubleshooting

Frequently asked questions

Where can I purchase a Dirac Live license?

- You can purchase a Dirac Live license on the Dirac website (www.dirac.com/denon).

Can I apply Dirac Live to multiple AVRs with one Dirac Live license?

- No. Dirac Live licenses are registered to the AVR itself. To apply Dirac Live to multiple AVRs, you will need to purchase a license for each AVR.

My AVR is not detected by the Dirac Live software.

- Make sure your AVR and your computer are connected to the same network and that both can connect to the internet. “Connect to a network.” (🔗 p. 7)
- Restart the Dirac Live software.
- Restarting the device may improve the problem.
Continue pressing the ⏻ button on the unit until “Restart” appears in the display, or remove and re-insert the power cord of the unit.
- Your router or its settings may be incompatible with the Dirac Live software or your AVR. Use a different router or check the settings of your router.

Can Dirac Live measure crossover frequencies?

- Dirac Live Room Correction does not support automatic measurement of crossover frequencies. You will need to manually configure the settings in the AVR setup menu before or after measuring.
- You can use the additional Dirac Live Bass Control or Bass Management function to automatically set crossover frequencies.
You can also adjust them in the Filter Design screen. “9-2 If using Bass Management or Dirac Live Bass Control™” (🔗 p. 14)
- When using the additional ART feature, the crossover frequency cannot be specified. Use the ART parameters to adjust the bass.

Can target curves be edited offline?

- No. Your AVR needs to be connected to your computer to edit target curves.

An error message is displayed in the Dirac Live software.

- Make sure the Dirac Live software is updated to the latest version.
To check whether you are using the latest version, go to:
www.dirac.com/live/downloads/

I can't use Dirac Live filters.

- Dirac Live filters can be set in “Setup Menu” - “Audio” - “Dirac Live” or “Option Menu” - “Dirac Live”. “Setting up Dirac Live on this unit” (🔗 p. 19)



I can't find the Dirac Live filter(s) stored on my AVR anymore.

- Your Dirac Live filter(s) are automatically deleted on your AVR if you change your AVR's speaker configuration. For example, if you modify the Speaker Layout settings on your AVR, your filter(s) will be deleted.

To recover your filter(s):

Dirac Live filters do not work if the speaker configuration has been changed. You can either create new Dirac Live filter by performing a new Dirac Live calibration, or you can change your AVR's speaker configuration back to the initial Dirac Live calibration that the filter(s) were built for. If you go back to your previous Dirac Live calibration, you can access your original Dirac Live filter(s) stored on your PC and export again to your AVR.

What does the "Device data inconsistent or unsupported" error message on Dirac Live software mean?

- You will see this error message when the speaker configuration on your AVR has been changed. The Dirac Live software sees that the speaker configuration on your AVR doesn't match its stored configuration.

To troubleshoot this error, do one of the following:

- Set the speaker configuration back to the original.
- If you want to keep the new speaker configuration, you must reinitiate the Dirac Live calibration process to create new filters.

If you're sure that the speaker configuration has not been changed, but you're still getting the error message, try power cycling your AVR to see if the error message disappears. To power cycle, press and hold the AVR's power button for more than 5 seconds or unplug and plug back in the AVR.

Msg 180, error code 200004

Device data inconsistent or unsupported

The connection was refused due to the device reporting data that is either inconsistent or insufficient for use with Live.

If you are an end user, contact the manufacturer of your device. If you are the manufacturer, check the log for details.

Dismiss



Can I connect my PC to my AVR and perform Dirac Live calibration on my TV?

- You can connect your PC to your AVR via HDMI. However, once Dirac Live calibration starts, the AVR outputs the Dirac status screen (the image shown below) on your TV until the calibration finishes. You cannot continue to see your PC screen on your TV. You must use a separate PC monitor or a laptop for the calibration.

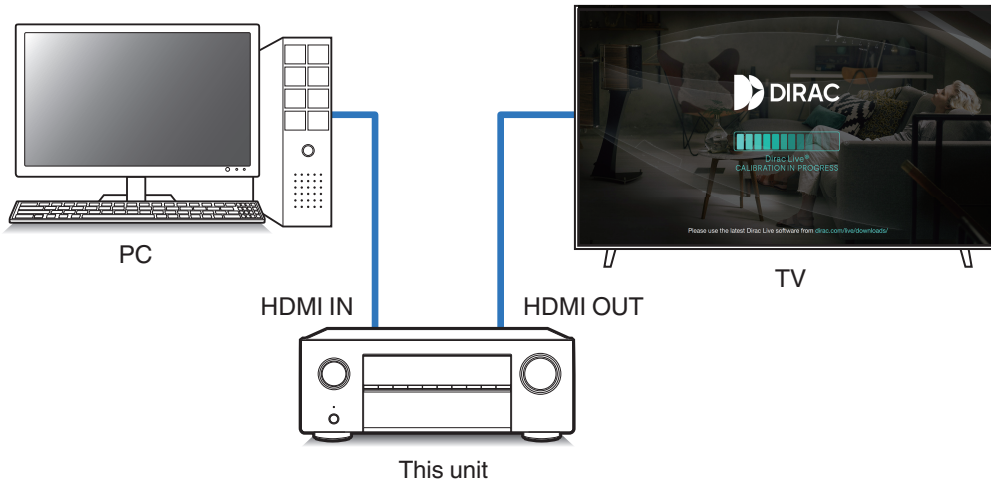

Can I use Dirac Live when my AVR is using pre-outs?

- Yes.

Can I use the Dirac Live iOS or Android app instead of the Dirac Live software for PC or Mac?

- Yes. However, during calibration, the app will not accept the built-in microphone on your iOS or Android device. Please have your choice of USB microphones, such as Mini DSP's UMIK-1, ready and connected to the AVR's front panel USB input to perform calibration.

! Invalid recording device.

AVR was selected to record measurements but has no recording capabilities.

Dirac Live requires a microphone connected to the audio device.

Dismiss



About Dirac Live Bass Control

Can I use the Dirac Live Bass Control function with a Dirac Live Room Correction license?

- No. You will need to purchase a Dirac Live Bass Control license in addition to your Dirac Live Room Correction license. “Dirac Live licenses and features” (👉 p. 6)

Can I combine a Dirac Live Bass Control license with the Limited Bandwidth license for Dirac Live Room Correction?

- Yes. You can combine it with the Dirac Live Rooms Correction Full Bandwidth license and the Limited Bandwidth license.

How can I tell if my Bass Control license is registered to my AVR?

- Use the Dirac Live software to connect to your AVR. When you open the Filter Design Page, you will find the available Dirac Live options. On the TV screen, it is not possible to check whether your AVR is registered for Bass Control.

Do I need to take measurements again in order to use Dirac Live Bass Control?

- If you have the project file from the last time you took measurements, you can simply load the project file in the Dirac Live software and skip the measurement. You can create a new Bass Control filter based on your previous measurement results. “Creating a filter using an existing project file” (👉 p. 18)

I can't change the speaker settings.

- Some speaker settings cannot be configured when using a filter where Dirac Live Bass Control is applied. To use these settings, turn off Dirac Live or select a filter where Dirac Live Room Correction is applied. “Setting up Dirac Live on this unit” (👉 p. 19)



About Dirac Live Active Room Treatment

Can I use the Dirac Live Active Room Treatment function with a Dirac Live Room Correction license?

- No. You need the Dirac Live Active Room Treatment license in addition to a Dirac Live Room Correction license. Purchase a DiracLive Bass Control license if you want to use subwoofers. “Dirac Live licenses and features” (👉 p. 6)

Can I combine a Dirac Live Active Room Treatment license with the Limited Bandwidth license for Dirac Live Room Correction?

- No. You can combine a Dirac Live Active Room Treatment license only with Dirac Live Rooms Correction Full Bandwidth.

How can I tell if my Active Room Treatment license is registered to my AVR?

- Use the Dirac Live software to connect to your AVR. You can see Dirac Live Options that are available to you when you open the Filter Design Page. It is not possible to use your TV screen to check whether your AVR is registered for Active Room Treatment.

Do I need to take measurements again in order to use Dirac Live Active Room Treatment?

- If you have the project file from the last time you took measurements, you can simply load the project file in the Dirac Live software and skip the measurement. You can create a new Active Room Treatment filter based on your previous measurement results. “Creating a filter using an existing project file” (👉 p. 18)

I can't change the speaker settings.

- Some speaker settings cannot be configured when using a filter where Dirac Live Active Room Treatment is applied. To use these settings, turn off Dirac Live or select a filter where Dirac Live Room Correction is applied. “Setting up Dirac Live on this unit” (👉 p. 19)

Can I set the crossover frequency?

- No. The settings are automatically optimized by using ART parameters instead of the crossover frequency to maximize the capabilities of your speakers.

What is the frequency range of ART?

- ART specifically operates within the frequency range of 20 Hz to 150 Hz.

Is it okay to set a lower frequency of ART operation than the playback frequency of the speakers?

- No. If you want to specify the ART parameters manually, check the specifications of your speakers to ensure that the parameter settings do not go below the playback frequency of your speakers.

What is the minimum configuration of speakers required to use ART?

- You can use ART with a speaker system that has two or more units (stereo).

What kind of room is ideal for ART?

- ART performs optimally in rooms ranging from approximately 12 m² to 100 m² (130 ft² to 1100 ft²), including typical home environments, home cinemas, and studio control rooms.

How does ART differ from traditional room treatments?

- Unlike passive acoustic treatments like bass traps or diffusers, ART actively uses existing speakers to minimise room-induced resonances. This enables sophisticated control of the sound field that traditional treatments cannot practically achieve at very low frequencies.



Inquiries

Click the following link for more detailed information on Dirac Live.

www.dirac.com

If you experience trouble with anything not mentioned in this guide, please feel free to contact support team at

<https://www.dirac.com/contact/>

Trademark information



© 2018 Dirac Research AB. All rights reserved. Dirac, Dirac Live and the Dirac logos are trademarks of Dirac Research AB.



DENON[®]
www.denon.com

3520 10863 00ASE
©2023 DEI Sales, Inc. All Rights Reserved.