

DENON[®]

Dirac Live Room Correction

Ensure that your devices firmware is up to date to access all functionality in this manual.



Getting Started

Dirac Live	3
Measuring with Dirac Live	4
Equipment required for Dirac Live Room Correction	4
Configuring device settings	5
Measuring with Dirac Live software	6
Creating a filter using an existing project file	12

How to use

Setting up Dirac Live on this unit	13
Dirac Live	13

Tips

Troubleshooting	14
Frequently asked questions	14

Appendix

Inquiries	16
Trademark information	16



Dirac Live

This unit supports Dirac Live®Room Correction.

Dirac Live license for Dirac Live Room Correction need to be purchased in order to use these services.

■ What is Dirac Live Room Correction?

Dirac Live is the leading digital room correction solution used in premium home theaters by applying state-of-the-art, patented algorithms that analyze and digitally reduce room impact and enhance speaker performance.

Dirac Live delivers a larger sweet spot, accurate staging, clarity, voice intelligibility, and a deeper, tighter bass not otherwise possible.

■ Unique features of Dirac Live

- Runs on your PC/Mac computer
- User customizable target curves
- Save 3 customizable filters for easy comparison



- Refer to the information below to learn more about Dirac Live.

1. Dirac Live instruction top page
<https://helpdesk.dirac.com/>
2. Dirac Live software download page
<https://www.dirac.com/live/downloads/>
3. FAQ
<https://helpdesk.dirac.com/>



Measuring with Dirac Live

Equipment required for Dirac Live Room Correction

■ Computer (Windows or Mac)

You will need to install Dirac Live software on your computer in order to measure with Dirac Live Room Correction.

Your computer must have an internet connection.

■ Microphone for measurements

A USB microphone (sold separately) is required in order to measure with Dirac Live Room Correction. If your microphone comes with a calibration file, make sure the calibration file is available.

Recommended microphone: mini DSP UMIK-1*

* Download the unique calibration file for your UMIK-1 from the miniDSP web site by entering its serial number. Please select the “_90deg” file.

Calibration file download

Serial number: -

<https://www.minidsp.com/products/acoustic-measurement/umik-1>

NOTE

- If you need a USB extension cable for the UMIK-1, please use an ACTIVE USB 2.0 or 3.0 cable.

Recommended USB Extension cable: Cable Creation Active USB Extension Cable 16.4 FT

<https://www.cablecreation.com/products/active-usb-extension-cable-16-4-ft>

■ Microphone stand

- For best results do NOT use the miniature mic stand that comes with the UMIK.
- Use a standard boom mic stand (sold separately).
- Do not hold the microphone in your hand while taking measurements.

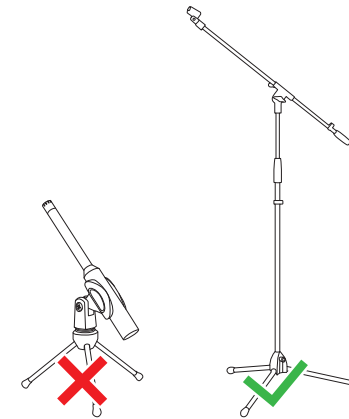

NOTE

- The microphone should be mounted on a stand facing the ceiling.

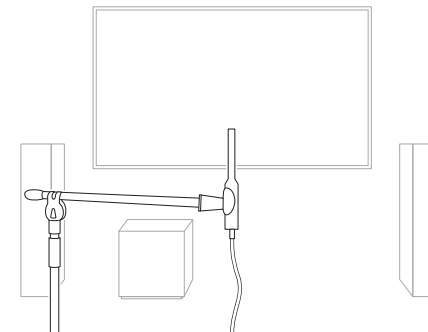

■ Dirac Live account, Dirac Live license and Dirac Live Software

If you are using Dirac Live Room Correction, you will need to create a Dirac Live account, purchase a Dirac Live license, activate your Dirac Live license and download Dirac Live software from following web page.

www.dirac.com/denon/



- You can create a Dirac Live account by selecting “Don’t have an account?” in the login screen of the Dirac Live web page.
- Make sure the Dirac Live software is updated to the latest version.
To check whether you are using the latest version, go to:
www.dirac.com/live/downloads/

Make sure you are also using the latest version of the software on your device.
Go to
Settings - Software Update - Check for Update in the HEOS App.

Configuring device settings

Before using Dirac Live software, follow the steps below to set up this unit.

1 Connect to a network.

Connect this unit and the computer where Dirac Live software is installed to the same network.

(Setting items: Setup Menu - Network - Connection)

2 Set up the speakers.

Please set up each speaker according to the speaker configuration you will actually use.

NOTE

- The optional Dirac Live room correction feature calculates the proper gain and delay time for each speaker, however it does not calculate the crossover points. Please adjust the crossover points for your speakers using the device’s Settings Menu before performing Dirac Live calibration.
Setting Item: Settings – [your device name] – High Pass Filter/Wired Subwoofer – Low Pass Filter (If you are using a wireless subwoofer, please configure from [your Subwoofer name] –Low Pass Filter.)



Measuring with Dirac Live software

The Dirac Live software is used for the measurement. Follow the instructions in the Dirac Live software to take the measurements.

1 Start the Dirac Live software.

2 Log in to your Dirac Live account.



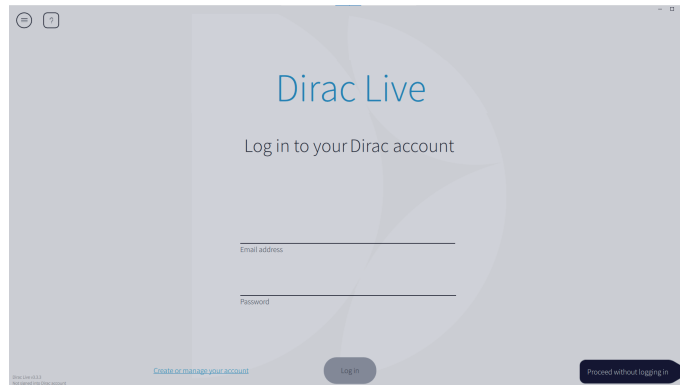

Enter the account details you created on the Dirac Live website.

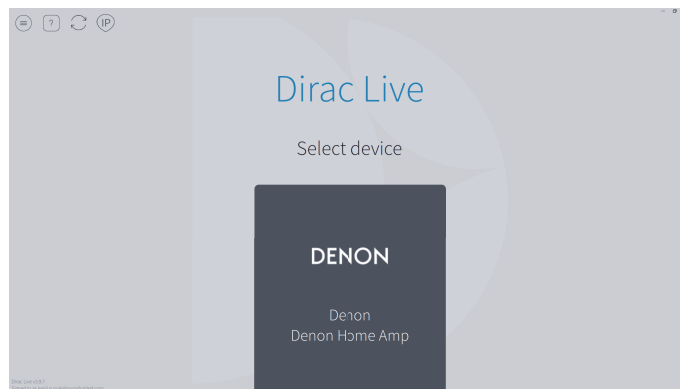

3 Select the product you want to take measurements for.

The software detects products compatible with Dirac Live on the same network as the computer and displays them on the screen.



- If this unit cannot be found, click  (Rescan).
- Click the  (IP) button to detect this unit manually by entering the IP address.
- Click the  (Menu) button to display the menu. This allows you to select the language and save and import projects.
- Click the  (Help) button to view a help page for each screen.

■ If you have already taken measurements with Dirac Live

You can skip the measurement process by loading the project file you saved with your previous measurements after selecting this unit. “Creating a filter using an existing project file” ( p. 12.)



4 Connect the microphone that will be used for the measurements to a USB port on the computer.

The microphone is displayed in the Dirac Live software when it is connected.

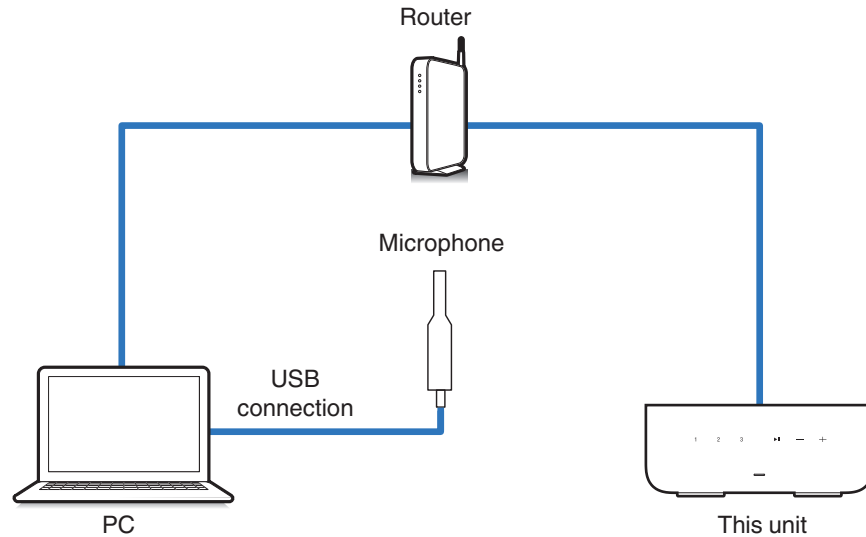

5 Select the microphone you will use for the measurements.

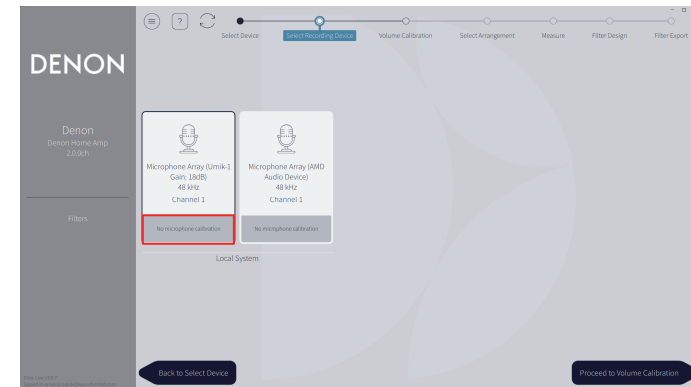

If the microphone you are using for the measurements comes with a calibration file, you will need to load the calibration file in the Dirac Live software too.

- Click “No microphone calibration” of the microphone (shown in red) to load the calibration file.

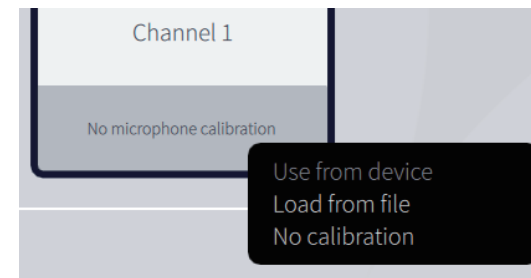

After selecting the microphone, click “Proceed to Volume Calibration”.

NOTE

- The internal microphone of the computer and other recording devices connected by USB are also displayed. Be sure to select the microphone you connected for these measurements.



6 Adjust the output level for the measurements and the input level for the microphone.

Adjust the output of the speakers that are connected to a suitable level so that proper measurements can be taken.

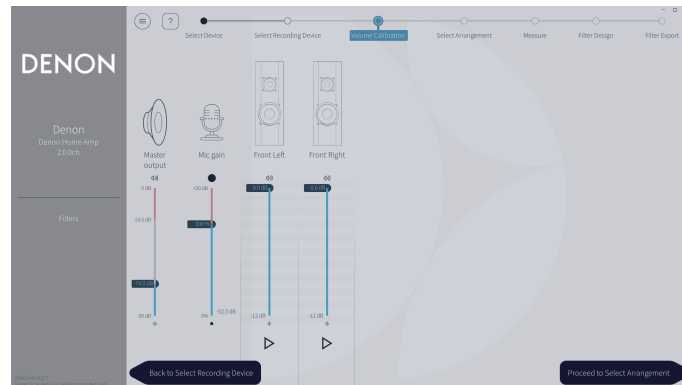

- ① Put the microphone you will use for the measurements on the microphone stand and place the stand at the main listening point.
Point the tip of the microphone toward the ceiling and adjust the height to match the height of the ears of a listener in a seated position.
- ② Set Mic gain to 100%.
- ③ Set Master output to around -74.0dB.
- ④ Select one speaker and press the ▶ button.
A test tone will be output from the speaker you selected and the audio that is detected will be displayed on a level bar.
- ⑤ Adjust the master output so that the audio that is detected is around -15.0dB to -30.0dB.
- ⑥ Play the test tone of the next speaker and check that the output displayed in the level bar is between -15.0dB and -30.0dB.
If it is outside this range, adjust the output level using the volume controls for each channel in the Dirac Live software.
- ⑦ Repeat step 6 for all of the speakers and adjust each speaker so that the output level is between around -15.0dB and -30.0dB. When you have finished adjusting the output levels, click “Proceed to Select Arrangement”.

NOTE

- The output displayed on the level bar is a guide only, and the level bar may not reach -30dB depending on your computer or environment. In this case, adjust all channels to approximately the same level.
Set the volume level a little higher than the level you would typically use.
- When a wired subwoofer is connected to this unit, you cannot adjust the subwoofer volume on this screen. Please adjust the volume directly on the subwoofer itself when adjusting the volume of each speaker. You can also change the volume in the HEOS app. Wired subwoofers are not measured individually, but are measured simultaneously with each speaker.
Also, wireless subwoofers are not measured.



About the main listening position

- The main listening position is the position where listeners would normally sit or where one would normally sit alone within the listening environment.
- To ensure that the measurement results are correct, put the microphone for measurement on a microphone stand.



7 Select a listening area

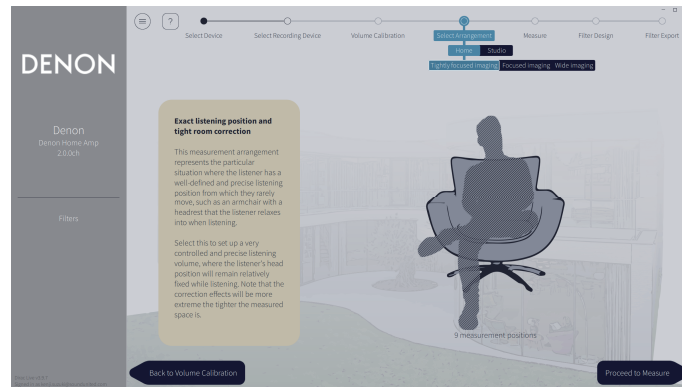

After selecting the listening area, click “Proceed to Measure”.

NOTE

- Use the “Wide Imaging” arrangement in Dirac Live if your room has more than one row of seating or is large enough for more than two people.

8 Take the measurements.

Take measurements in each position.

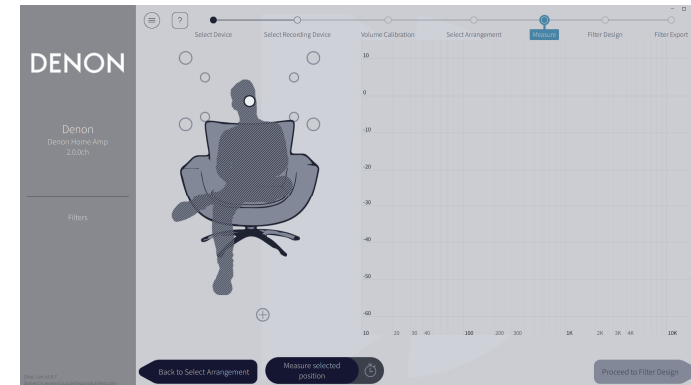

- ① Put the microphone you will use for measurement in the main listening position and point it straight upward.
- ② Select the circle in the center of the illustration on the screen.
- ③ Click “Measure Selected position”.
A test tone will be output from each speaker and the measurement will start.
- ④ When the measurement is finished, move the microphone to the next position.
- ⑤ Select the next position on the screen and take the measurement.
- ⑥ Repeat steps 4 and 5 to take measurements in all of the positions.
When you have finished taking the measurements, click “Proceed to Filter Design”.



NOTE

- You can proceed to the next step (“Filter Design”) without taking measurements in every position. However, we recommend taking measurements in every position, because the more measurements that are taken, the more accurate the calibration is.
- Keep the room as quiet as possible during measurements. Other noise will interfere with measurements. Close the windows and turn off electrical products (radios, air conditioners, fluorescent lights, etc.) Noise from these products may affect measurements.
- Do not stand between the speakers and the microphone or place large items there while taking measurements.

9 Adjust the filters.

Adjust the filters of each channel.

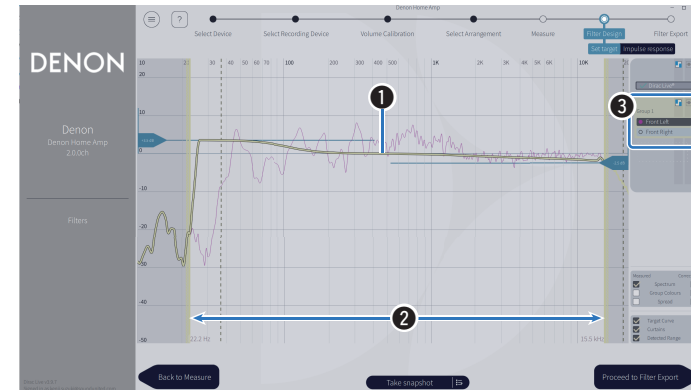
**1 Target curve**

The target curve is the curve used to decide the frequency characteristics of the speakers after calibration by Dirac Live. You can adjust the target curve according to your preferences.

2 Curtains

Use the sliders on the screen to adjust the frequency range across which the filter will be applied.

3 Speaker selection

Select the speaker for which you want to edit the target curve. You can also group together specific speakers. The same target curve will be applied to all of the speakers in the group.

When you have finished adjusting the filters, click “Proceed to Filter Export”.



10 Export a filter to this unit.

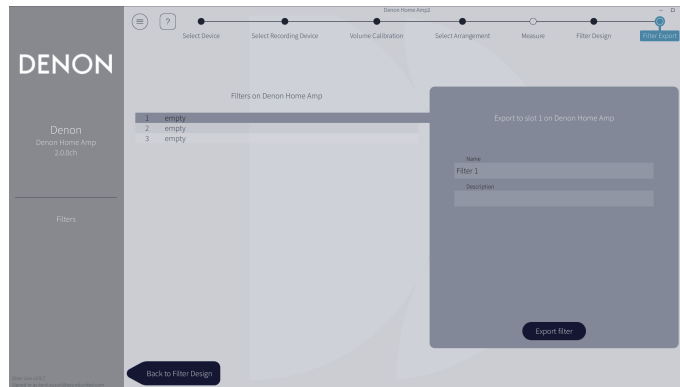

- ① Select the slot of a filter you want to export.
- ② Enter a name for the filter.
You can enter any name in Dirac Live software, but this unit has a character limit. We recommend entering a name that is 20 characters or less.
- ③ Click Export Filter.
The filter is exported to this unit. The Filter Design page is displayed automatically when the export is completed.

11 Create multiple filters.

Up to three filters can be created in Dirac Live according to the measurement data. After creating new filters in the Filter Design page, select the numbers of unused slots in the Filter Export screen and export the filters.

NOTE

- You can save and import measurement projects at any time from the menu in the Dirac Live software. Saving a project file allows you to resume measurements if they are interrupted or export measurement results again if necessary.
- If you try to overwrite an exported filter with the same filter after editing it manually, there may be some cases in which the saved settings are not applied. In this case, select the filter you want to overwrite from “Filter” displayed in the lower left of the Dirac Live software screen. The filter can be deleted from this unit by clicking the X mark. Then export a new filter.

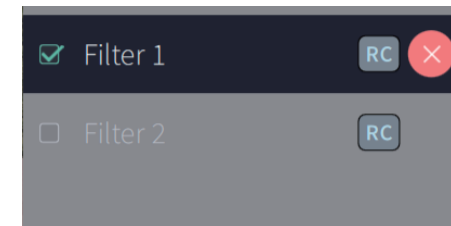

Creating a filter using an existing project file

If you have a project file with earlier measurement results, you can load this project file to adjust a filter without taking measurements.

1 Select the menu in the Dirac Live software.

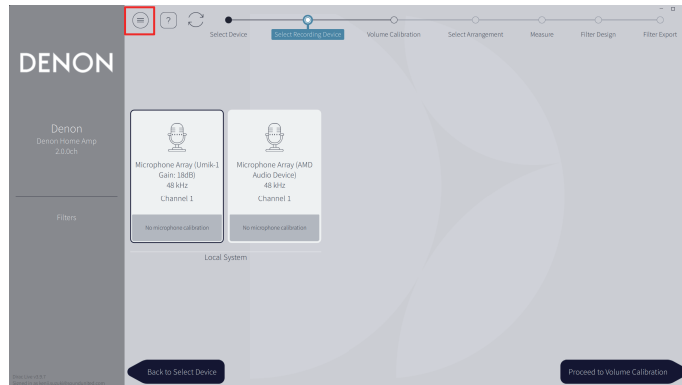

3 Adjust the filter

After the project is loaded, a screen to adjust the filter opens. Adjust the filter for each channel. “Adjust the filters” (👉 p. 10.)

2 Load the project file

Select Load Project in the menu and then select the project file you want to use. (The file must have the extension “.liveproject”.)

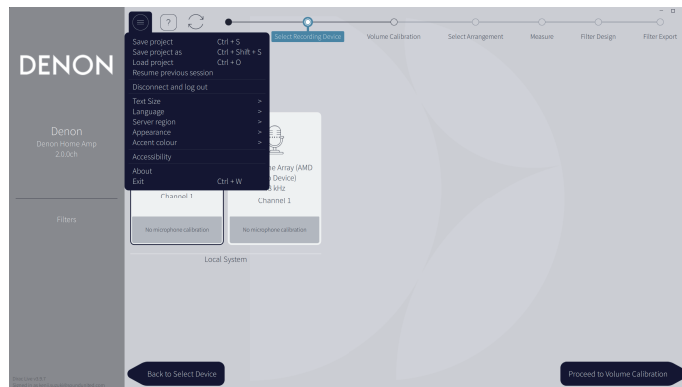

Setting up Dirac Live on this unit

Dirac Live

Filters exported from the Dirac Live software can be set by selecting Now Playing - Sound Options - Dirac Live Filter in the HEOS App.

These settings are enabled after the filter is sent to the unit from the Dirac Live software.

Slot 1*:	The Dirac Live filter that was exported to Slot 1 will be used.
Slot 2*:	The Dirac Live that was exported to Slot 2 will be used.
Slot 3*:	The Dirac Live that was exported to Slot 3 will be used.
Off:	Dirac Live filter will not be used.

* Filter names created in Dirac Live Software will be displayed in the user interface.



- You can store a maximum of 3 filters when using Dirac Live Software.
- Only the slot to which the filter was exported can be selected.
- When the sound mode is "Direct", the acoustic filter will not be applied.
- When using a Dirac Live filter, you cannot set the HEOS app's "Settings" – "My Devices" – "Output Mode" to "Dual Mono Settings". If you select "Dual Mono Settings", the Dirac Live filter will be Off.



Troubleshooting

Frequently asked questions

Where can I purchase a Dirac Live license?

- You can purchase a Dirac Live license on the Dirac website (www.dirac.com/denon).

Can I apply Dirac Live to multiple devices with one Dirac Live license?

- No. Dirac Live licenses are registered to the device itself. To apply Dirac Live to multiple devices, you will need to purchase a license for each device.

My device is not detected by the Dirac Live software.

- Make sure your device and your computer are connected to the same network and that both can connect to the internet. “Connect to a network.” (👉 p. 5)
- Restart the Dirac Live software.
- Restarting the device may improve the problem.
Remove and re-insert the power cord of the unit.
- Your router or its settings may be incompatible with the Dirac Live software or your device. Use a different router or check the settings of your router.

Can Dirac Live measure Low Pass Filter and High Pass Filter?

- Dirac Live Room Correction does not support automatic measurement of Low Pass Filter and High Pass Filter. You will need to manually configure the settings in the device settings menu before measuring.

Can target curves be edited offline?

- No. Your device needs to be connected to your computer to edit target curves.

An error message is displayed in the Dirac Live software.

- Make sure the Dirac Live software is updated to the latest version.
To check whether you are using the latest version, go to:
www.dirac.com/live/downloads/

I can't use Dirac Live filters.

- Dirac Live filters can be set in HEOS App, “Now Playing” - “Sound Options” - “Dirac Live Filter”. “Setting up Dirac Live on this unit” (👉 p. 13)



Can I use the Dirac Live iOS or Android app instead of the Dirac Live software for PC or Mac?

- Not available. For measurements using iOS or Android Dirac Live apps, it is necessary to connect a measurement USB microphone to the device being measured, but this unit does not support connection to USB microphones.

! Invalid recording device.

AVR was selected to record measurements but has no recording capabilities.

Dirac Live requires a microphone connected to the audio device.

Dismiss

Although a subwoofer is connected, the subwoofer is not displayed in the Dirac Live app.

- Even when a subwoofer is connected to this unit, the subwoofer will not be displayed in the Dirac Live app. Wired subwoofers are measured simultaneously with each speaker. Also, wireless subwoofers are not measured.



Inquiries

Click the following link for more detailed information on Dirac Live.

www.dirac.com

If you experience trouble with anything not mentioned in this guide, please feel free to contact support team at

<https://www.dirac.com/contact/>

Trademark information



© 2018 Dirac Research AB. All rights reserved. Dirac, Dirac Live and the Dirac logos are trademarks of Dirac Research AB.



DENON[®]
www.denon.com

3520 11024 00AS
©2025 Masimo.com All Rights Reserved.